

# MotorGuide REPAIR PARTS

**Model:**  
**ZX55**

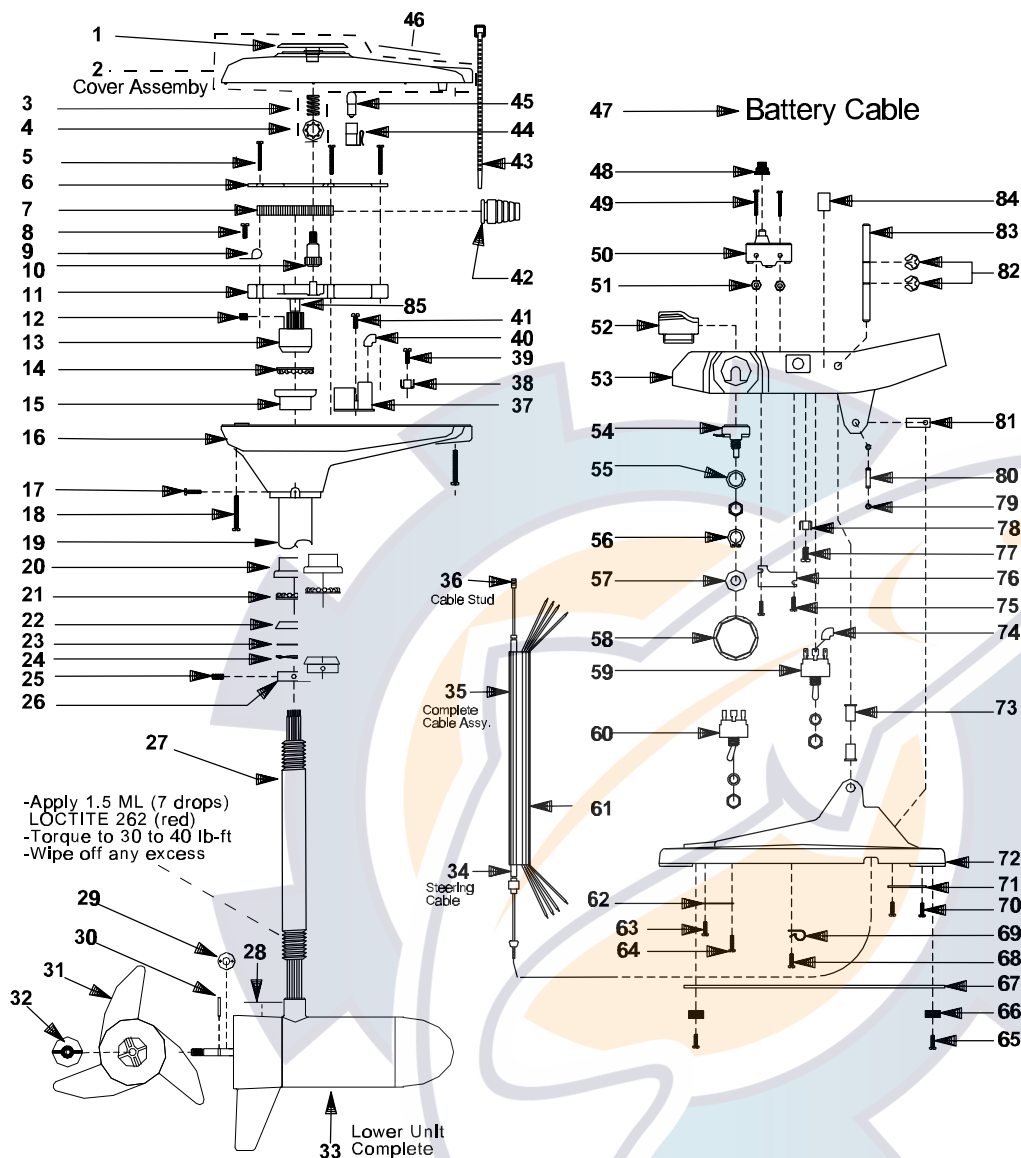

**SPECIFICATIONS:**

- Year of Intro 1998
- Thrust 56LBS
- Volts 12/24VDC
- Amp Draw 0 to 34amps
- Mount 20 Bow
- Speeds 10 Forward

**QUICK REFERENCE PARTS GUIDE:**

- Momentary switch AP151-01
- Toggle Switch FP153-03
- Motor Seal Kit 6220
- Rotary Switch HF150-01

**PARTS ORDERING & TECH ASSISTANCE**

MotorGuide Consumer Relations  
Phone 918-831-6989  
Fax 800-982-8093

**Send Returned Goods to:**

MotorGuide  
605 Hwy 12 West  
Starkville, MS 39760

*Returned Goods must be accompanied with a Returned Goods Authorization. Contact MotorGuide Consumer Relations to obtain RGA.*

KEY	DESCRIPTION	PART #	KEY	DESCRIPTION	PART #	KEY	DESCRIPTION	PART #
1	RED INDICATOR	AF078-08	31	PROP/ 3 BLADE	AF124-10	58	5 SPEED KNOB	LP082-07
2	T/H COVER COMPLETE BLACK	BF053-13	32	PROP NUT	AR099-01	59	TOGGLE SWITCH 3 POSITIONS	FP153-03
3	COMPRESSION SPRING	AF014-01	33	F/O MOTOR WR	BF397-03	60		
4	TINNERMAN CLIP	AF046-01	34	63" CONTROL CABLE STUD ASY	9377	61	69" ELECTRIC CABLE JACKET	MM9006-03
5	#6 RACK GUIDE SCREW	AF133-01		69" CONTROL CABLE STUD ASY	9767	62	63" ELECTRIC CABLE JACKET	MM9006-02
6	RACK GUIDE COVER	AF127-01	35	63" CONTROL CABLE ASY	AP327-16	63	CABLE PLATE	KP123-01
7	RACK	AP125-01		69" CONTROL CABLE ASY	AP327-18	64	#6 SELF TAP SCREW	EK135-01
8	#10 x 1/2" SCREW	GR133-01	36	CONTROL CABLE STUD	AP141-01	65	6 X 1/2 SCREW	AF135-01
9	CABLE CLAMP	AP036-01	37			66	6 X 1/2 SCREW	AF135-01
10	INDICATOR GEAR	AF069-01	38			67	FOOT PEDAL PAD	KP023-01
11	RACK GUIDE	AF126-01	39			68	WEIGHT PLATE ASY	LP3123-01
12	1/4 NUT SET SCREW	AF142-01	40			69	6 X 1/2 SCREW	AF135-01
13	PM PINION NUT	AF398-02	41			70	CABLE CLAMP	KP036-01
14	BEARING	FM005-01	42	GROMMET	AP071-01	71	SCREW	IR133-01
15	BEARING CUP	AF007-01	43	CABLE TIE	AF030-01	72	BATTERY CLAMP	KP036-02
16	T/H BASE BLACK	AF004-07	44	LAMP HOLDER	AF394-01	73	FOOT PEDAL BASE	LP003-01
17	#6 SELF TAP SCREW	EK135-01	45	LAMP	AF093-01	74	SHAFT BUSHING	KP021-01
18	SCREW #8 X 3/4	LF141-03	46	NOMENCLATURE	BF056-09	75	INSULATING SLEEVE	AT080-01
19	42/50" OUTER TUBE	AF165-06	47	BATTERY CABLE ASY WITH PLUG	LP328-	76	6 X 1/2 SCREW	AF135-01
20	BEARING CUP	FM007-01	48			77	RETAINER PLATE	LP123-03
21	BEARING	FM005-01	49	MICRO SWITCH BOOT	KP157-01	78	#10X1/2 SCREW	GR133-01
22			50	#6 32 X 1 1/2 SCREW	LP135-01	79	TERMINAL 4 PRONG	FT160-03
23			51	MICRO SWITCH	AP151-01	80	E RING	FP046-01
24			52	6 - 32 NUT S.S	SP098-02	81	CABLE PIVOT PIN	AP105-01
25	CONE SET SCREW	AF143-01	53	MICRO BUTTON	LP026-01	82	CABLE PIVOT	LP091-01
26	BEARING CONE	AF006-01	54	FOOT PEDAL HI MARINE	LP101-03	83	.312 E RING	BK046-02
27	42" .105 SS F/O COLUMN	AF049-09	55	ROTARY SWITCH	HF150-01	84	FOOT PEDAL ROCKER PIN	LP102-01
28	LOWER UNIT DECAL BEAST	ET060-04	56	LOCK WASHER 3/8	KP171-01	85	12/24 DECAL	LP057-04
29	MONOFILAMENT WASHER	AR175-01	57	GRIP RING	LP046-01		PINION NUT BUSHING	AF021-01
30	PROP DRIVE PIN	BR102-01		NYLON WASHER	AK171-02			

# LOWER UNIT BREAKDOWN

Model:  
**ZX55**

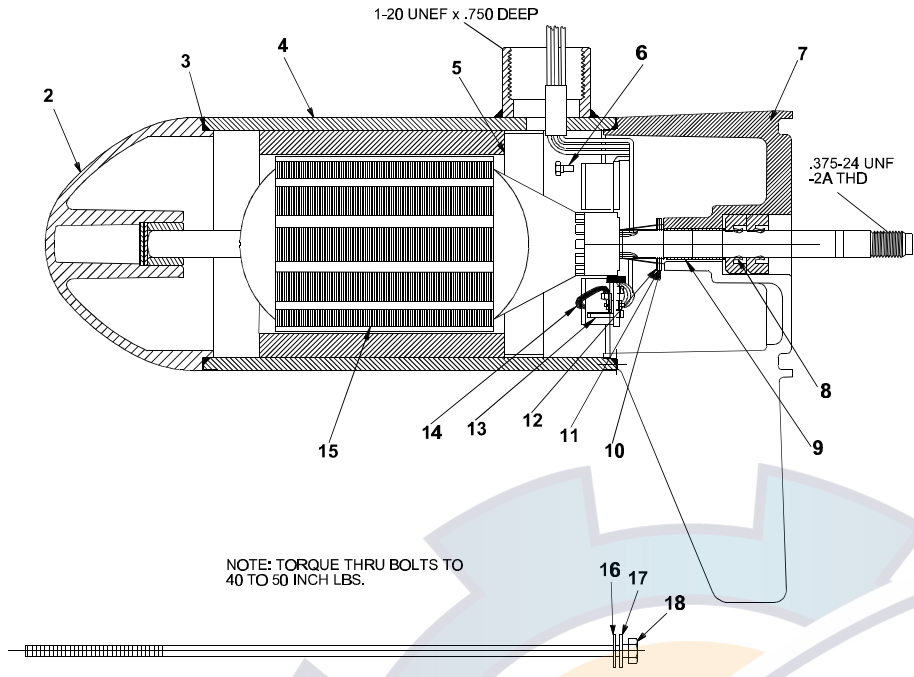

## WIRING

### 12/24V WIRING DIAGRAM

